

NHN[®] PDC100 series



FEATURES

The NHN PDC100 pivot closer is the first in the Flagship Range from NHN's next generation of hidden door closers.

Incorporating the latest cam type technology, the NHN PDC100 pivot closer offers easy opening with increased efficiency on the closing torque.

The closing speed is easily adjusted via two independent adjustment valves.

Available with or without hold open at 90°.

Narrow style with high performance.

Easy installation; cost and time saving as no preparation on the floor needed.

5 year Guarantee against faulty workmanship.

- Suitable for a glass door up to 100 kg (220 lbs).
Glass thickness
PDC100(S) : 8-13mm (5/16 - 1/2 in.)
PDC105(S) : 10-15mm (3/8 - 9/16 in.)
Door width
PDC100(S) : 750-1000mm (29 1/2 - 39 3/8 in.)
PDC105(S) : 750-1250mm (29 1/2 - 49 3/16 in.)
- Supplied non handed the NHN PDC100 provides optimum efficiency with quick and easy installation.
- Simple final adjustments; 3mm (1/8 in.) backward/forward, 3mm (1/8 in.) left/right, ± 4° alignment.
- Ambient temperature from -20°C to +50°C (-4°F to +122°F).
- Finishes available as standard are satin and polished stainless steel. (Other finishes available on request.)

SELECTION CHART / FUNCTION & ADJUSTMENT

SELECTION CHART

MODEL NO.	Function	Door width	Door weight	Max. opening angle
PDC100	Non-hold open	1000mm (39 3/8 in.)	100kg (220lbs)	150°
PDC100-S	Hold open 90°			90°
PDC105	Non-hold open	1250mm (49 3/16 in.)		150°
PDC105-S	Hold open 90°			90°

1

Double action

Non hold open model PDC100/105:
Maximum opening angle 150°

Hold open model PDC100-S/105-S:
Hold open position and maximum
opening angle 90°

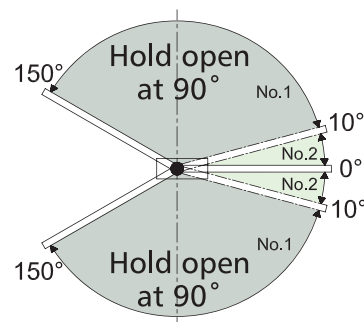

2

Two speed adjustment

Closing speed (150°~ 10°)
Latching speed (10°~ 0°)

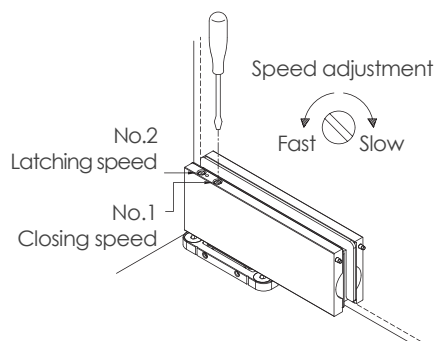

3

Providing over 70% efficiency, the NHN PDC100 combines light opening with smooth closing.

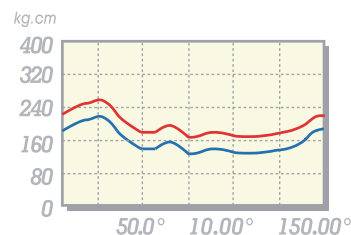

INSTALLATION

Below shows the installation dimensions for PDC100/100S. (For 105/105S, please refer to the manual provided with the unit.)

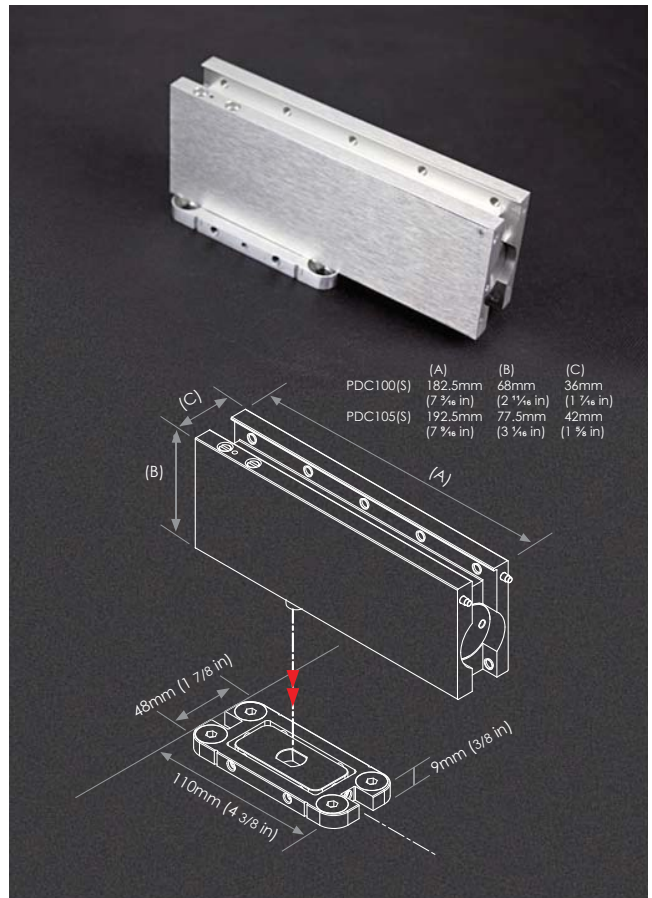
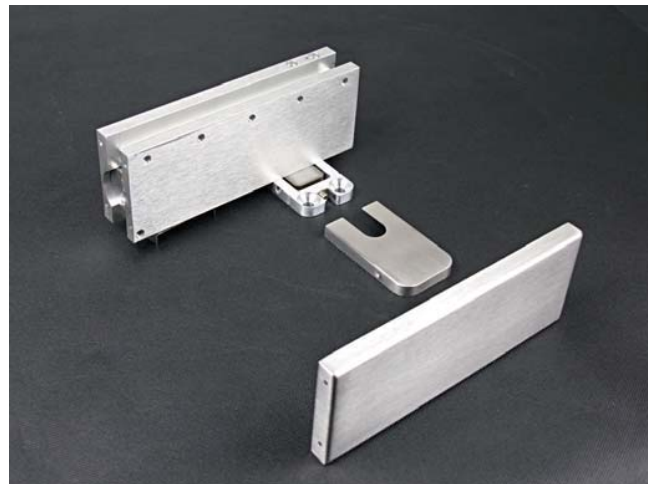
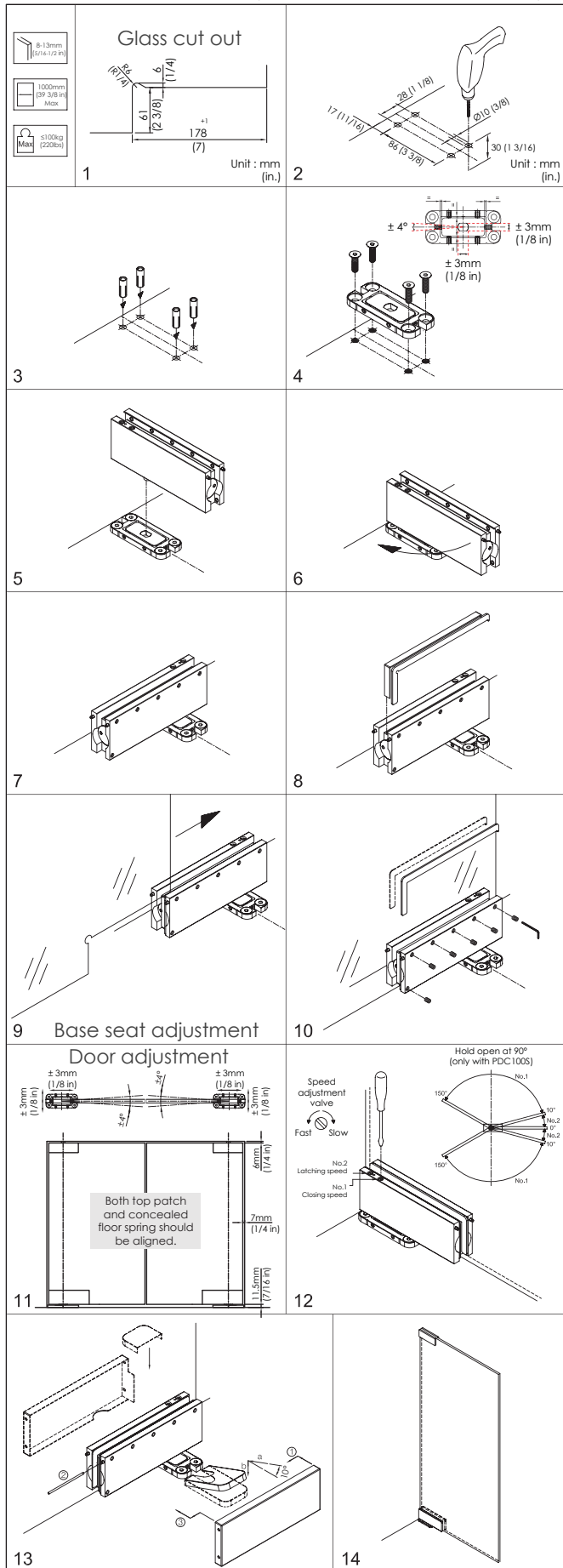

STANDARD COMPONENT

PDC100 PIVOT DOOR CLOSER w/ BASE PLATE



MOUNTING HARDWARE



OPTIONS

TP1 TOP PIVOT



KPF-1 CORNER PATCH



KPF-4 WALL MOUNT TRANSOM PATCH

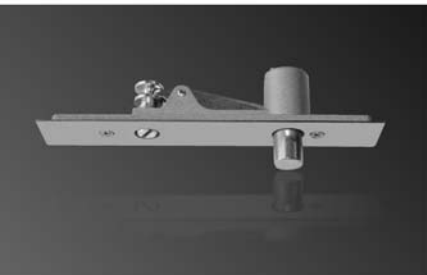

Max. glass thickness of KPF- series glass patches is 13mm (½ in).



KENWA CO., LTD.

NH[®]
Closing Solutions

6th Floor, Marutake Honmachi Building
6-18 Honmachi 1-Chome, Chuo-ku
Osaka 541-0053 Japan

P: +81-(0)6 6265 1130

F: +81-(0)6 6265 1132

E: info@kenwa.co.jp

www.kenwa.co.jp

www.micomautodoor.com

E.&O.E. All sizes, photo's and drawings are subject to change without prior notice.
Copyright © 2013 KENWA CO.,LTD. OSAKA JAPAN All Rights Reserved.

DISTRIBUTED BY



KENWA TRADING CORP.

380 N BROADWAY SUITE 302
JERICHO, NY 11753, U.S.A.

P: +1-516-933-6016

F: +1-516-933-6018

E: ktc@kenwa.net

http://kenwa-america.com